

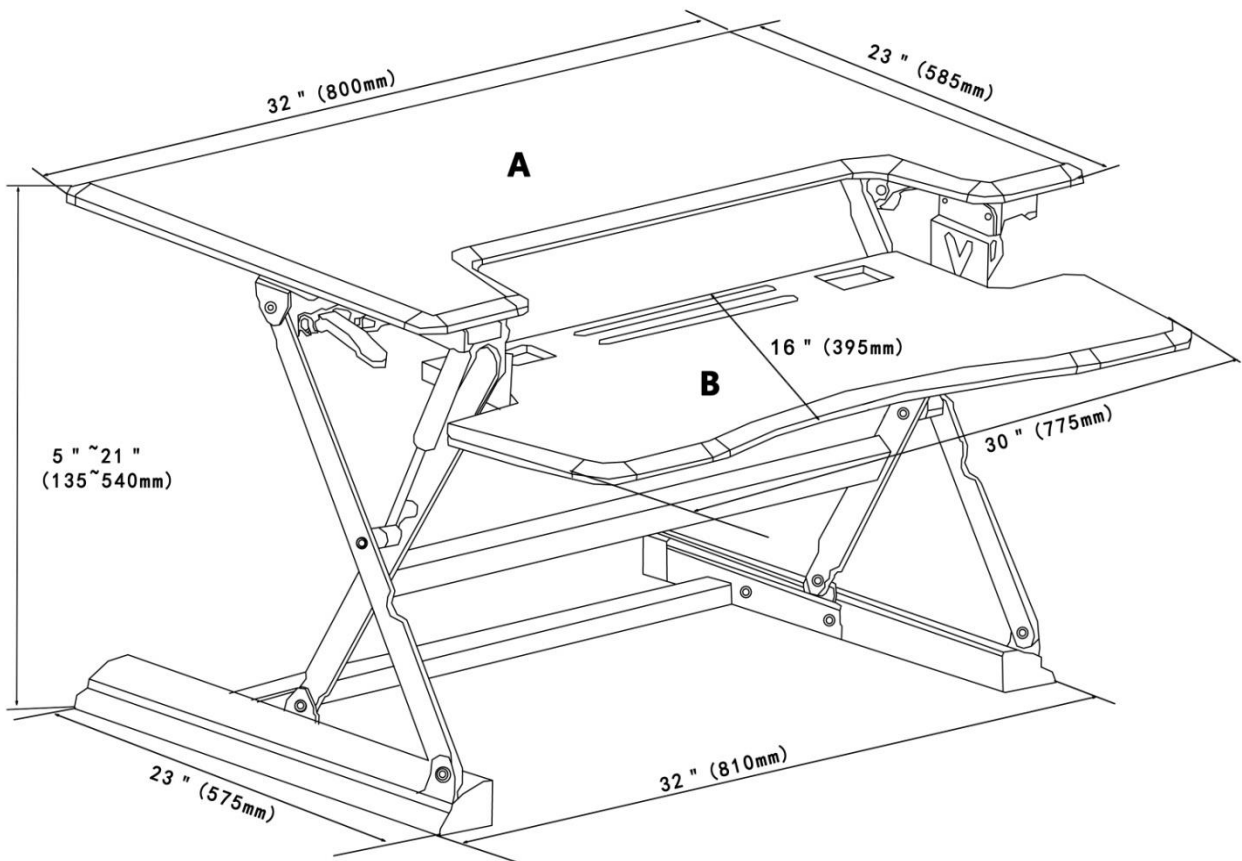

# casiii

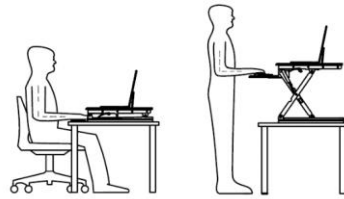

## UP32 Height Adjustable Sit-Stand Workstation

Specifications:

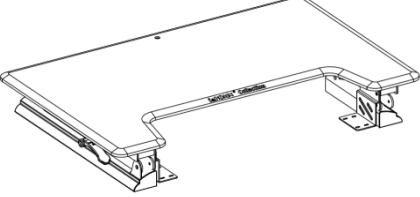
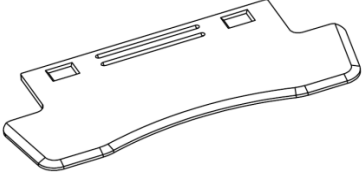

**Max Capacity:** Desktop =  $\leq 35$  lbs, Keyboard tray B =  $\leq 15$  lbs

## Parts List:

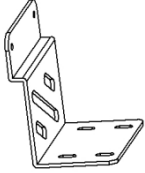
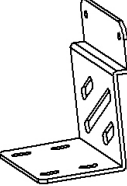
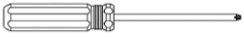
 <b>Desk</b>		 <b>Keyboard Tray</b>	
 <b>Screws(8 black) (Step 4)</b>	 <b>Left Bracket</b>	 <b>Right Bracket</b>	 <b>Screwdriver</b>

## Remove the Desk from Box

Warning: The desk is heavy, we recommend two people to remove it.



1. Open the box, take out the desk and place on the table.

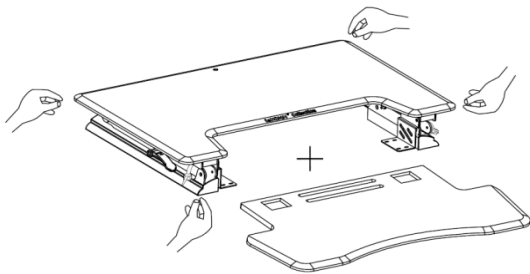

2. Remove the cable ties on two sides.

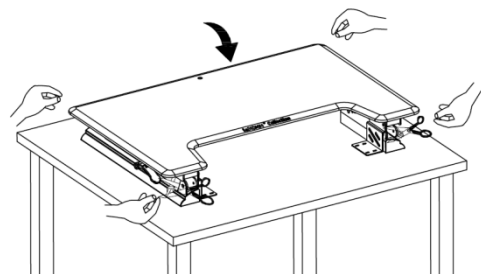

## Install Keyboard Tray

3. Adjust the desk to the suitable height, put the keyboard tray into the brackets position, and make sure it's horizontal.

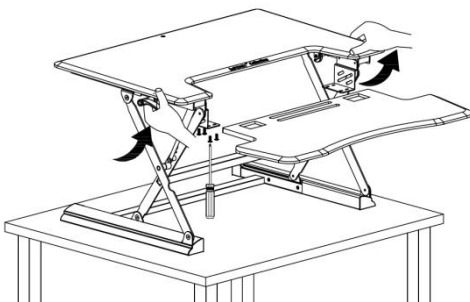

4. Use the screwdriver to attach the keyboard tray to the desk with 8 black screws.



## Operating Instructions



**Warning: Avoid Pinching!** Please don't put your hands on the supporting bars, as they move during adjustment and may cause injury.

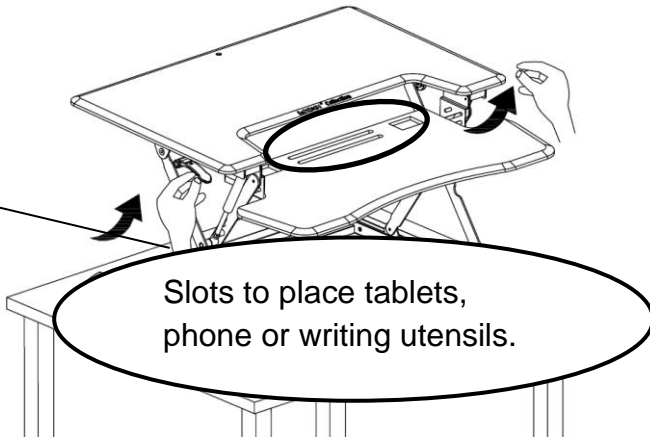

5. Raising and lowering the desk by squeezing both handles at the same time.

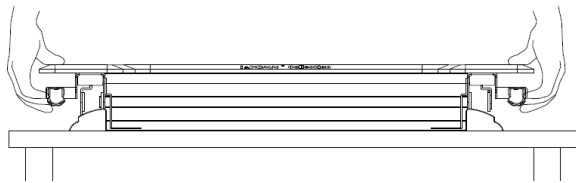

### 6. Raising Tips

A: Grip the left and right handles at the same time.

B: Raise the desk to the desired height.

C: Release handles and ensure desk has locked into position.

### CAUTIONS :

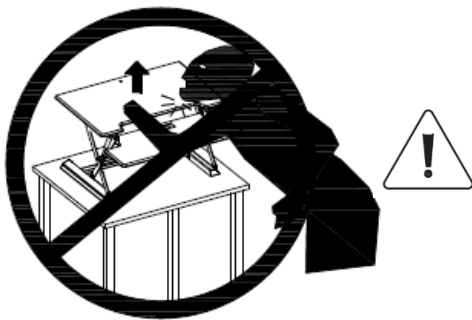

When setting up your desk, raise it to the maximum height to ensure that it can be adjusted without causing damage to your equipment.



Make sure all equipment is properly situated on the desk. Overhanging monitors or other equipment can fall, resulting in damage or injury.



When using the adhesive Cable Ties, make sure that you leave enough length in the cable to allow for the full height adjustment.

